

INSTRUCTION MANUAL

PHILCO R-F SIGNAL GENERATOR

MODEL 7070

SPECIFICATIONS

FREQUENCY COVERAGE

- R.F.100 kc. to 110 mc. (six bands)
- Audio400 cycles
- R-F Output Amplitude .6—1 volt (r.m.s.), depending upon range
- A-F Output Amplitude 1 volt (r.m.s.) approx.
- Calibrationdirect reading
- Operating Voltage110—120 volts, 60 cycles, a.c.
- Power Consumption25 watts
- Tube Complement1—6C4, 1—7F8, 1—6X5GT
- Pilot Lamp6—8-volt, Part No. 34-2040

The Philco R-F Signal Generator, Model 7070, is designed for precision alignment work, and for many tests employed by the radio-service technician and the laboratory engineer. In the design of this new generator, every effort has been made to attain a maximum of frequency stability, with ample output, combined with portability.

Unusual freedom from r-f leakage and radiation has been achieved, by careful attention to the shielding and filtering of power-line leads.

Special design and shielding of attenuator components give the instrument an excellent control of output, permitting meticulous adjustments on highly-sensitive receivers. Complete control of r-f output, from the highest to the lowest amplitude, is obtained through the operation of the two rotary controls, the MULTIPLIER and the ATTENUATOR.

A new feature is the cathode-follower r-f output-coupling system, which affords excellent isolation for the r-f oscillator, to improve frequency stability.

The six-band r-f output provides complete coverage from 100 kc. to 110 mc.—all fundamental frequencies.

The busy serviceman will appreciate the new-style output-cable termination—a convenient bakelite terminal box with two spring-action binding posts for attaching the connector clips, the dummy antenna, or a cable terminating resistor. No more repairing to do on broken leads and shielding at the business end of the cable.

The built-in audio modulator furnishes a 400-cycle audio test-signal output, of excellent wave shape, having many applications in the service laboratory.

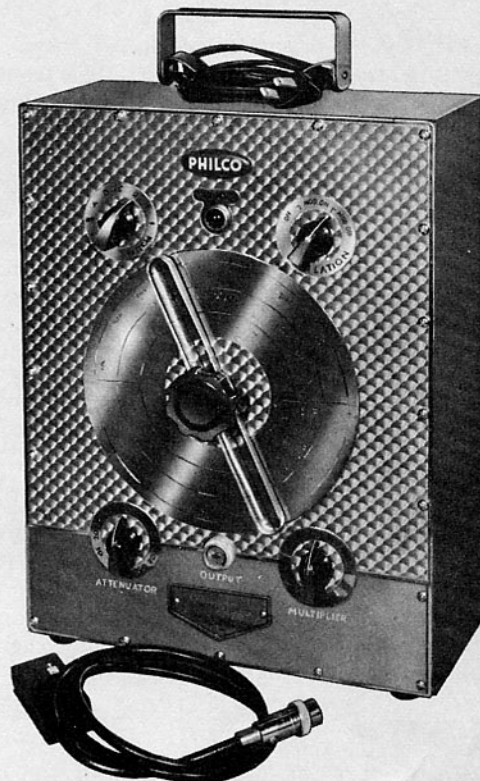

TP-3738

FREQUENCY COVERAGE BY BANDS

Band	Range
A	100 kc. to 310 kc.
B	300 kc. to 950 kc.
C	900 kc. to 3.1 mc.
D	2.9 mc. to 10.5 mc.
E	10 mc. to 35 mc.
F	34 mc. to 110 mc.

CALIBRATION ACCURACY.—The calibration is accurate within $\pm 1\%$ of the scale reading.

FREQUENCY STABILITY.—Operating tests have proven that, after the initial warm-up period, frequency drift does not occur in excess of $\frac{1}{2}$ of 1% during four hours of continuous operation. When the modulation is switched on or off, carrier frequency shift is less than 1/100th of 1%.

LINE VOLTAGE.—The Model 7070 Signal Generator will operate satisfactorily with line voltages of 105 to 125, a.c. Within these limits the frequency of the generator output will hold to within ½ of 1% of the dial calibration.

ATTENUATION CHARACTERISTICS.—With the ATTENUATOR and MULTIPLIER controls in minimum positions, and with the output cable terminating in a load of 70 ohms, less than 5 microvolts of signal at any frequency is found at the output end of the cable.

LINE FILTER.—To prevent r-f signal energy from being fed into the a-c line, the Model 7070 Generator is provided with a shielded, two-section, modified pi filter.

OUTPUT CABLE.—The 36-inch output cable is a high-quality, low-loss coaxial cable, equipped with a bakelite terminal box at the output end; this box (containing only the cable connections) has two spring-action binding posts for attaching the connector clips, the dummy antenna, and, whenever necessary, a cable terminating resistor.

CIRCUIT DESCRIPTION

The Philco R-F Signal Generator, Model 7070, contains a six-band r-f oscillator covering all frequencies from 100 kc. to 110 mc., a 400-cycle audio oscillator for modulation of the r-f signal and for separate audio output, a cathode-follower output stage, and the power supply. The audio output is controlled by the same attenuator system used for the r-f output.

R-F OSCILLATOR

On bands A, B, C, D, and E, covering 100 kc. to 35 mc., the 6C4 r-f oscillator tube operates in a tuned-grid, untuned-plate circuit (see figure 17). Resistance stabilization of the oscillator is employed; this control method, of long-established use in laboratory work, affords an r-f output of excellent wave shape, and a stability of frequency that makes the circuit substantially independent of line voltages and tube replacements.

On the highest frequency band (F), the same 6C4 tube operates in a Colpitts oscillator circuit; the high-frequency coil* is permanently connected to the tuning condensers and the grid of the oscillator tube. The presence of these components has no effect on the efficiency of the tuned-grid, untuned-plate circuit. The combining of these two oscillator circuits makes the high-frequency oscillator available without actually switching its vital elements. This feature insures reliable operation, since switch-contact resistance is avoided, and shorter leads are possible.

When any one of the five lower frequency bands is selected, the band switch automatically grounds the

* Note: The high-frequency coil is made from a 7/8-inch length of No. 10 copper wire.

grid sections of the remaining coils, to prevent absorption of r-f energy at any frequency of the range in use.

CATHODE FOLLOWER

The output of the r-f oscillator is fed through condenser C111 to the grid in one section of the 7F8 tube. This section functions as a cathode follower, minimizing the load on the oscillator, and providing low-impedance output. The r-f output is taken from the cathode and fed to the attenuator, R116.

The r-f output signal is modulated by applying the modulation to the plate circuit of the cathode follower. This is done by supplying the plate current through a part of the plate winding of the modulator transformer in the audio-oscillator circuit. This method of modulating the r-f signal is particularly effective in avoiding the introduction of frequency modulation—a feature that insures more accurate results with the procedures for adjusting FM detector circuits, as described under FM ALIGNMENT. It will be noted that the modulation level for different bands is controlled by the position of wafer BS-1(R) of the band switch. This wafer is so connected that, in certain positions, the series plate resistor R110 is used either with or without the plate shunt condenser C117 to attenuate modulation, while in other positions, R110 is shorted out to furnish a maximum modulation signal at the plate of the cathode follower. Thus, an average of 30% modulation is maintained for all bands.

A-F OSCILLATOR

For the audio output and modulation, the remaining section of the 7F8 tube operates in an Armstrong oscillator circuit. Sufficient degeneration is employed to develop an output wave shape of good characteristics, with minimum distortion content. For audio output alone, the signal is taken from the plate circuit of the tube, through the tap on transformer T100, and fed through C115 and R115 to the attenuator.

ATTENUATION

The ladder-type attenuation system employs a network of eight fixed resistors, with a multiple-point switch for step adjustments and a 1000-ohm carbon-type potentiometer for fine adjustments. This system eliminates the necessity for separate high-power and low-power output jacks, and provides a low-impedance output circuit. The entire system is efficiently shielded to eliminate direct or indirect pickup from the oscillators.

POWER SUPPLY

The power supply employs a power transformer, a 6X5GT full-wave rectifier tube, and the filter circuit. Two sections of an electrolytic condenser and a pair of 5600-ohm resistors, in parallel, comprise the filter.

HOW TO OPERATE THE MODEL 7070 SIGNAL GENERATOR

1. CONNECTING TO POWER SOURCE

Insert the power-cord plug into a 105-125-volt, 60-cycle power source. Turn on the power by turning the MODULATION control to MOD. ON.

2. CONNECTING OUTPUT CABLE

Insert the plug of the output cable into the OUTPUT jack on the front panel. Connect the two output clips to the circuit to which the signal is to be supplied; the ground connection, identifying the shielded lead of the cable, is marked on the cable terminal box. For details on making connections to various types of circuits, refer to the information given on applications of the Signal Generator.

3. R-F OUTPUT

Allow the Signal Generator to warm up for *at least* ten minutes, to stabilize the frequency of the output signal. Turn the MULTIPLIER control to 1, and set the ATTENUATOR control about midway.

Locate the desired frequency on the calibrated dial and turn the tuning knob until the indicator line coincides with this mark. Note the identifying letter of the frequency band selected (letters above and below the tuning knob), and turn the BAND SWITCH to the corresponding letter.

Adjust the output by setting the MULTIPLIER control for the approximate level required, and making the fine adjustment by turning the attenuator control. When unmodulated output is desired, turn the MODULATION control to MOD. OFF.

4. AUDIO OUTPUT

Turn the MULTIPLIER control to 1, and set the ATTENUATOR about midway. Turn the BAND SWITCH to AUD. Turn the MODULATION control to MOD. ON. Adjust the output in the same manner as for r-f output.

CONNECTING GENERATOR TO AC/DC RADIOS

If connections are not properly made to AC/DC radios, a-c modulation may be mixed with the generator input signal, making testing or alignment difficult. For AC/DC sets having no direct connection between the common negative connector bus (one side of a-c line) and the chassis, connect the ground lead of the generator to the common connector bus; care should be taken to prevent this connection from shorting across to the chassis or to other circuits.

For AC/DC sets having the common negative bus connected to the chassis, the signal-generator ground

lead may be connected to the chassis in the usual manner.

In cases where the generator ground connection is much more conveniently made to the radio chassis, it is sometimes possible to reverse the polarity of the radio power plug to obtain a satisfactory minimum of a-c modulation.

APPLYING R-F SIGNAL TO R-F AND I-F CIRCUITS

For testing circuits by the signal-substitution method, where the main interest is centered in pushing a signal through, it may be said, in general, that the coupling method is not too critical, provided that sufficient coupling is available. Therefore the generator output lead may be directly connected to the circuit for many applications in signal testing (the built-in series condenser provides d-c voltage blocking). However, for alignment, and for circuit testing in which the circuit tuning at the point of connection must be as nearly undisturbed as possible, consideration should be given to the manner of coupling the generator to the circuit.

It should be noted that, the nearer the generator connection to the high-potential end of a coil, the greater the chance of detuning that circuit (also any circuit to which the coil is coupled). This condition occurs because the low-impedance generator-output circuit appears as a near short circuit, in effect, when improperly coupled to high-impedance circuits. Therefore to avoid this condition, the generator must be loosely coupled to the circuit; this can be done by the use of a small series condenser in the output lead, or by attaching the output clip to an insulated portion of the lead into which the signal is to be fed. Figure 1 illustrates several self-explanatory examples of signal-generator coupling to various types of circuits.

If it is possible to connect the signal generator ahead of the circuit to be tested or aligned, so that the signal must first pass through a tube, then it is unnecessary to employ a special coupling method.

APPLYING A-F SIGNAL TO AUDIO CIRCUITS

The same principles outlined above apply to the methods of coupling the signal generator for audio testing. Most of the audio circuits to which the signal is supplied by the generator are high-impedance circuits; therefore, when it is desired to make tests without causing undue disturbance to high-impedance circuits, the output lead should be connected through a small series condenser. Usually the selection of a capacity between 100 mmf. and .001 mf. will be found satisfactory.

As in the case of r-f and i-f circuits, however, if the signal can be made to pass through a tube to the circuit under test, no special precautions need be taken,

and the generator output lead can be directly connected.

ALIGNMENT (AM)

Probably the most important application of the r-f signal generator in the radio service laboratory is for alignment. Since there are many special problems connected with this phase of servicing, it is hoped that the following suggestions will aid the serviceman in solving these problems and obtaining accurate results.

PRELIMINARY

Before starting the alignment, it is advisable to make all the necessary repairs that are possible, do all the dusting, cleaning of switch contacts (particularly the band switch, if required), etc.

All new tubes required should be installed before making the alignment, and the adjustments should be made with the same tubes that are to remain in the set.

To avoid much unnecessary labor, it is recommended that the following operations be made a routine, preliminary to the starting of all alignments:

1. *Inspect Tuning-Condenser Gang.*—If the plates are dirty or dusty, clean them with a pipe cleaner; if they are too closely spaced for the pipe cleaner, use a length of soft twine of suitable size, to which a piece of wire is attached, for threading the twine between the plates.

Inspect the spacing between stator and rotor plates. If the spacing is not uniform, it will be impossible to secure the proper tracking between r-f and oscillator circuits; also, the dial calibration will be incorrect. If non-uniform spacing exists, it is better to detect the condition before wasting a lot of time in attempting to make a satisfactory alignment.

Inspect the rotor wiper contacts; if these require cleaning, or if the spring tension needs to be increased by bending, this should be done before making the alignment, since a change in tension of these springs may affect the spacing of the condenser plates.

2. *Check Dial-Pointer Setting.*—The dial pointer should be adjusted to the proper index mark before starting the alignment. This adjustment is usually made with the tuning-condenser gang fully meshed. If in doubt about the proper method of indexing the pointer, consult the factory data for this information.

CONNECTING GENERATOR FOR I-F ALIGNMENT

Since the i-f circuits must be properly aligned before the adjustment of r-f circuits can be attempted, various methods of connecting the signal generator for i-f alignment will be considered first. The output meter should be connected to the audio output stage of the radio; the connection may be made to the plate of the output tube or the voice coil of the speaker.

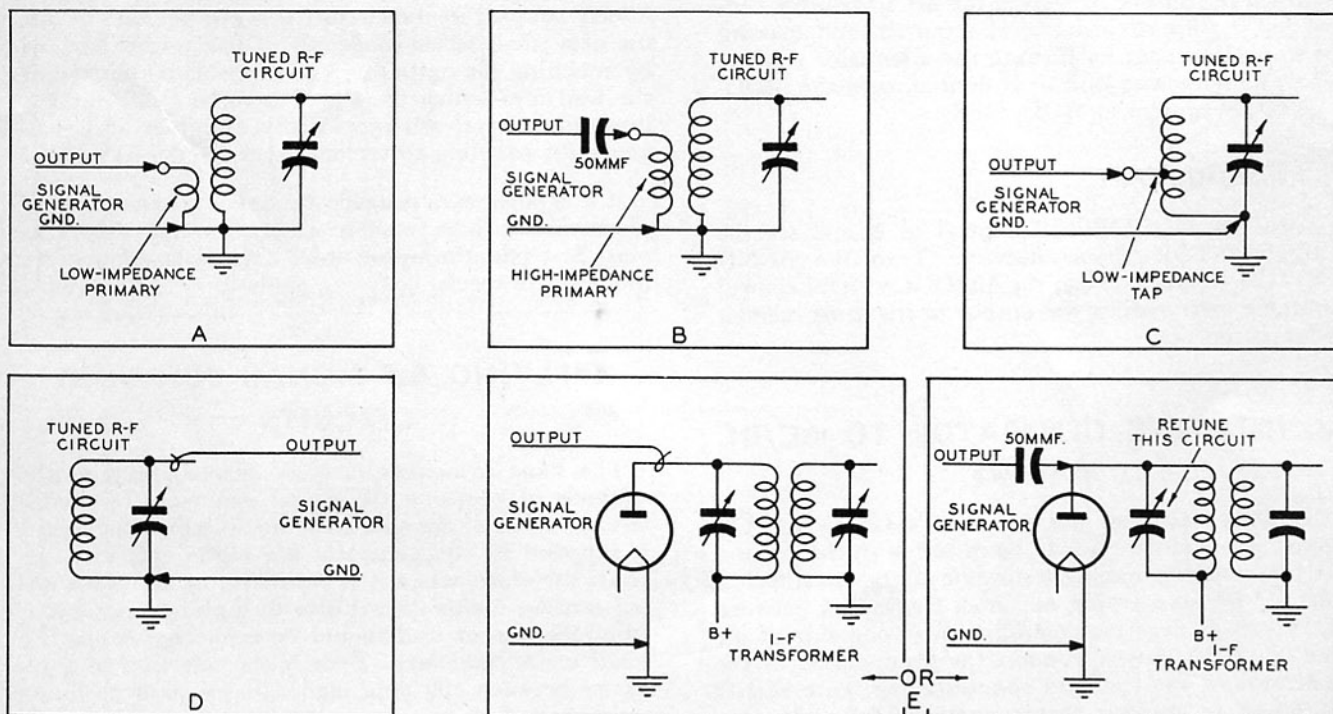

Figure 1. Connecting Generator to R-F and I-F Circuits

TP-2892B

During alignment, the input signal should be kept low; use just sufficient signal to produce a satisfactory output indication.

When aligning radios having loop aerials, it is difficult to prevent the set from picking up extraneous electrical noises, especially during the adjustment of r-f and oscillator circuits. The noise may, in some localities, be of sufficient intensity to cause an increase in a-v-c action, and to require signal-generator input in excess of the low value desired for accurate adjustments. Therefore, if the electrical noise background is high, wait until the condition clears up before making an alignment.

When making the i-f alignment, the radio band switch should always be set for standard broadcast (except for FM alignments).

To avoid confusing beat notes in the output signal from the radio, it is advisable to "kill" the oscillator by shunting a .1 mf. condenser across the plates of the oscillator tuning condenser.

CONNECTING TO AERIAL CIRCUIT

When the radio has no r-f stage, and employs an intermediate frequency of 455 kc., 460 kc., 470 kc., or some closely-related frequency, the i-f signal can usually be furnished in adequate strength by connect-

ing the signal generator to the aerial or loop circuit, and turning the tuning condenser gang until the plates are fully meshed. The generator may be connected as shown in figure 2 (A, B, or C).

When insufficient signal strength is obtained by this method, the generator may be connected to the converter grid circuit, as described below.

CONNECTING TO CONVERTER (FIRST DET.-OSC.) GRID CIRCUIT

The i-f signal may be fed into the converter control-grid circuit by connecting the generator output lead directly to the grid terminal of the tube. Usually, the most convenient point for this connection is the stator-plate terminal of the converter tuning condenser, as shown in figure 3A. There are certain radios, however, in which the tuned circuit of the converter is capacitively coupled to the control grid by a small condenser; in this type of circuit, if insufficient signal output is obtained by feeding the signal to the tuning condenser, the generator should be connected directly to the control grid of the tube, as shown in figure 3B.

The same condition created by the circuit of figure 3B is often noted when the radio band switch is set for short wave or FM. The reason for this is that, a tuned circuit (parallel resonant) in which the resonant

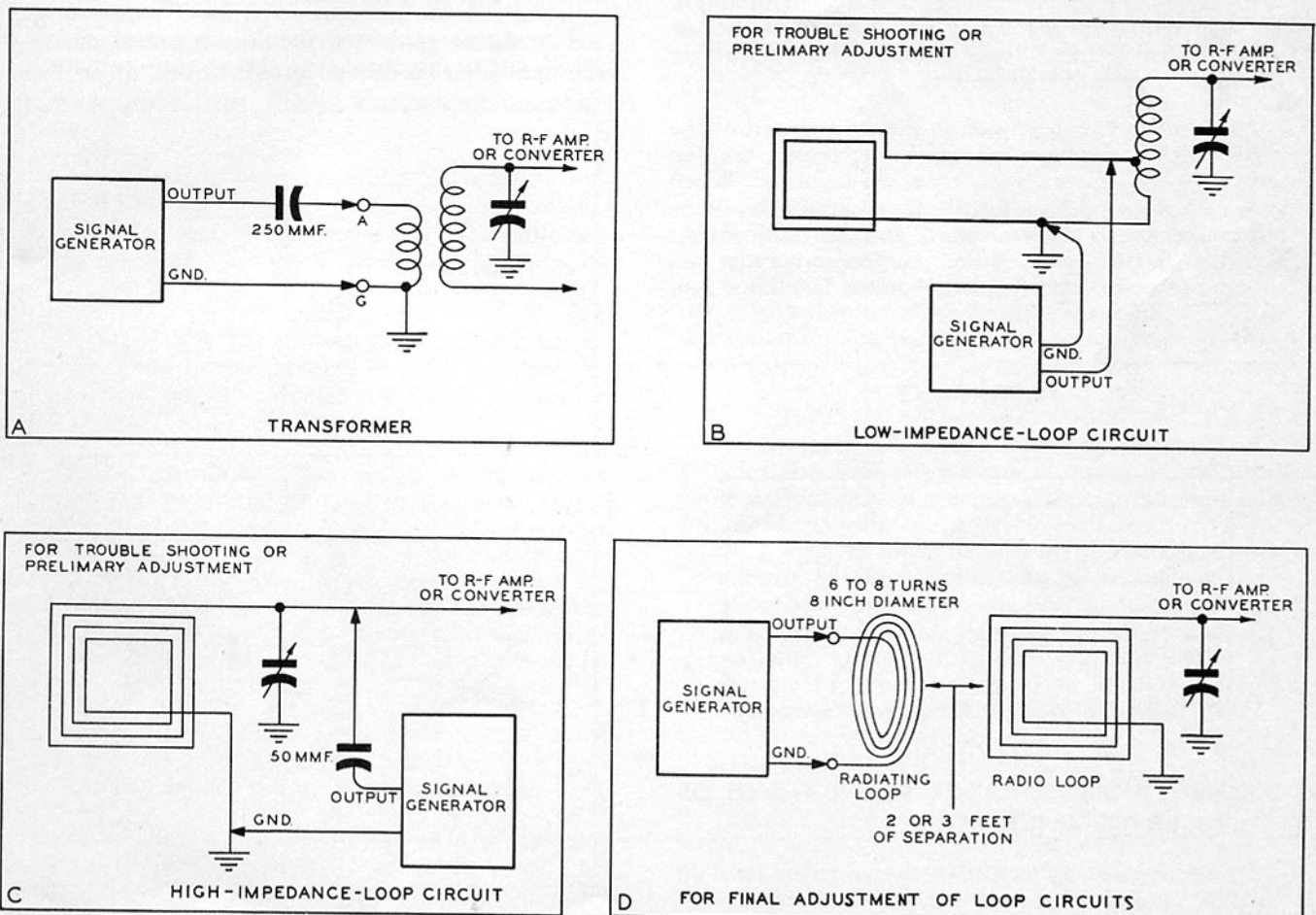

Figure 2. Connecting Generator to Converter Circuits

TP-2892C

frequency is greatly removed from the frequency of the input signal appears as a near short circuit to the output of the generator; therefore, by employing the reactance of the grid condenser in series with the tuned circuit, as shown, sufficient output signal voltage may be developed by the generator to satisfactorily operate the grid of the tube. In certain exceptional cases, particularly where the circuit does not use a grid condenser, it may be necessary to isolate the control grid from the tuned circuit by means of a 1-megohm series resistor (to provide a d-c grid-return path), and feed the generator signal directly to the control grid.

CONNECTING GENERATOR FOR STAGE-BY-STAGE I-F ALIGNMENT

Occasionally, the serviceman receives a set in which the circuits are so greatly out of alignment that the i-f signal cannot be heard when injected into the converter circuit. In such cases, the alignment must be made stage-by-stage, starting with the last transformer, using the following procedure:

1. Apply the i-f signal to the plate of the last i-f amplifier, connecting as shown in figure 1E, and tune the secondary and primary of the last i-f transformer.
2. Apply the signal to the grid of the last i-f amplifier, and retune the secondary and primary of the last i-f transformer; then tune the secondary circuit to which the generator is connected.
3. Connect the generator to the grid circuit of the preceding i-f amplifier, or converter, retune the last secondary adjustment, then tune the primary. When each i-f circuit has been tuned, the generator should be left connected to the converter, and each adjustment repeated in the same order (unless otherwise instructed in radio service manual), until maximum sensitivity is obtained.

IMPORTANT

If, during alignment, the radio develops oscillation when the adjustment approaches the point of maximum signal output, do not leave a trimmer detuned to avoid this condition. Oscillation in nearly all cases is caused by some defect in the radio—find the trouble and repair it, then start over again and make the complete alignment. The only exceptions to this rule occur in circuits having regeneration control, or in flat-top-tuned i-f circuits which require special methods of adjustment.

CONNECTING GENERATOR FOR R-F AND OSCILLATOR ALIGNMENT

Connecting the generator to the aerial or loop circuits of the radio involves one major consideration—injecting the signal without detuning the circuit. For this reason, the factory recommendations (when avail-

able) for the particular model of radio should be followed closely.

The alignment instructions will be found to specify certain dummy aerial components (capacitance or resistance) when required; these are connected to the generator output leads in series or in shunt.

Figure 2 shows methods of making connections to various types of aerial circuits.

For the final adjustment of loop circuits use the radiating loop, as shown in figure 2B; this loop should be placed far enough from the radio loop to eliminate any possible capacity effect between the two loops; 2 or 3 feet of separation is adequate.

When aligning the r-f and oscillator circuits of a radio having a loop, the loop should be so supported that its position with respect to the chassis of the radio is identical to its placement when both are mounted in the cabinet; otherwise, the r-f and oscillator circuits cannot be made to track properly. The final adjustment of the loop circuit should be made after the radio and loop have been re-installed in the cabinet.

ALIGNMENT OF SHORT-WAVE CIRCUITS

The adjustment of a short-wave circuit is more critical than that of a broadcast circuit.

The signal generator should be connected to the aerial circuit according to the factory recommenda-

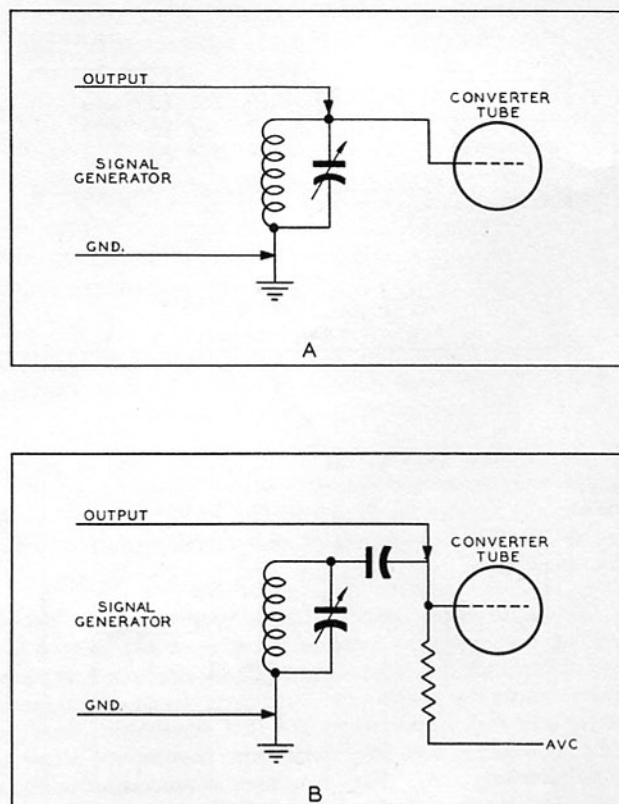

TP-2892D

Figure 3. Connecting Generator to Aerial Circuits

tions for the particular model of radio. For aligning high-frequency circuits, the generator leads, between the contact clips and the terminal box, must be kept as short as possible. If specific instructions are not available, the generator may be connected in the manner most commonly used, i. e., with a 400-ohm non-inductive (carbon or metallized) resistor in series with the generator output lead. For communications receivers, or others designed for transmission-line connection to a dipole-type aerial, connect a 70-ohm non-inductive resistor across the terminals of the signal-generator output cable.

When adjusting short-wave trimmers, use an all-fibre adjusting tool. Make the final adjustment of each trimmer screw a *tightening* motion—the adjustment will be much more permanent when made in this way.

There is nearly always a certain amount of "interlocking" action between the adjustment of oscillator and converter trimmers; therefore, after setting the oscillator frequency, always rock the tuning knob of the radio while adjusting the converter trimmer.

Always repeat the adjustment of oscillator and r-f circuits until no further improvement can be obtained.

NOTE: It is recommended that a 68 or 70 ohm, ¼ watt terminating resistor be bridged across the output terminals of the generator cable whenever band E or F is in use; this will reduce reflections in the output cable, thereby minimizing peaks or dips that might occur at various frequencies. Since this resistor removes the d-c isolation afforded by the blocking (coupling) condenser in the attenuator box, the resistor should be removed when connecting the generator output to a circuit in which a high d-c potential appears across the output terminals. The terminating resistor should be removed for 400-cycle audio output or for bands A, B, C, and D.

FM ALIGNMENT

Whenever possible, the alignment of FM circuits should be made according to the procedure given in the service manual for the particular radio.

There may be some occasions when the serviceman does not have specific alignment data on hand, or when the service manual specifies FM alignment equipment (FM signal generator and oscilloscope) which is not available.

To satisfy the need for information on the proper use of the ordinary type of amplitude-modulated signal generator for adjusting FM circuits, the following procedures are presented. It is possible to align practically any FM circuit with the AM generator, provided the generator has the necessary frequency coverage (particularly the high-frequency ranges), such as afforded by the Philco Model 7070.

The serviceman should understand what is taking place when the various circuits are tuned; therefore,

the following brief description of the functioning of FM tuned circuits should be studied before making any of the adjustments.

FM I-F CIRCUITS

The essential difference between an i-f transformer for FM and one used for AM (aside from the operating frequency) lies in the width of the band of frequencies that is passed by the amplifier in which the transformer is incorporated. High-fidelity AM reception requires an overall amplifier band width of 10 kc. (shown by the response curve of figure 4), whereas the band width required for FM is approximately 250 kc. Most of the FM i-f amplifier systems in use today are designed to provide a fairly flat response over this band (see figure 5), thus insuring high-fidelity reproduction.

The wide-band flat-top response characteristic is usually obtained in the design of the i-f transformers, the most common method of achieving this result being "overcoupling" of the coils.

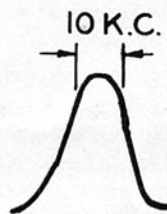
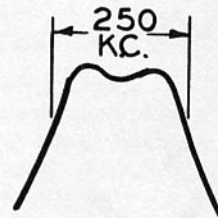

Figure 4



Part of TP-2892F

Figure 5

OVERCOUPLED I-F TRANSFORMERS

When the tuned primary and tuned secondary of a transformer-coupled stage are placed in inductive relationship with one another, there is a certain degree of coupling which produces maximum energy transfer without causing two maxima; this is "critical coupling." With this type of coupling, the response characteristic of the combined circuits, if shown graphically, might appear similar to the curve in figure 6. A transformer with this type of coupling can be tuned by merely adjusting the trimmers for maximum output. Now, if the coils are moved further apart (loose-coupled), it will be found that, although the maximum output of the stage is decreased, the tuning of the two circuits remains unchanged.

Now, if the two windings are brought closer together, past the point of critical coupling, the transformer is said to be "overcoupled." This type of coupling reduces the gain of the stage at the center frequency, but develops a somewhat flat-topped response characteristic, as indicated by the curve of figure 7.

An i-f transformer of the overcoupled type cannot be tuned by merely adjusting the trimmers for maximum output, as this can only be done by throwing one, or both, circuits off the correct center frequency.

If the adjustment were attempted in this manner, a response characteristic similar to that shown by the curve in figure 8 would result; the presence of the two sharp peaks can be determined by tuning the signal generator slowly across the intermediate frequency while watching the output or tuning indicator.

Obviously, then, the correct method of obtaining proper alignment of overcoupled stages with an AM generator is to loosen the transformer couplings to some value below critical coupling. This can be done quite easily, without changing the physical placement of the coils, by means of a loading network. This load may consist of a 5000-ohm non-inductive resistor in series with a .1-mf. condenser (the condenser is used

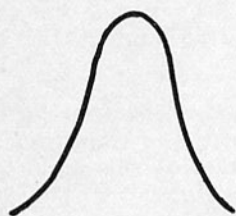

Figure 6



Part of TP-2892F
Figure 7

for d-c blocking), connected across the transformer winding from its high-potential end to the chassis (see figure 9). The shunt resistance reduces the magnetic field of the coil, thereby effectively changing the coupling between the two coils to below the critical value. The circuit that is *not* loaded may now be accurately adjusted by tuning it for maximum output indication. By transferring the loading network to the circuit which has been tuned, the opposite circuit of the transformer can then be adjusted. This method gives good uniformity of response, and proper flat-top characteristics since these qualities are determined by the original design of the transformers.

The response characteristic of each stage must, in itself, satisfy the condition for complete passage of the FM signal without imposing distortion on the

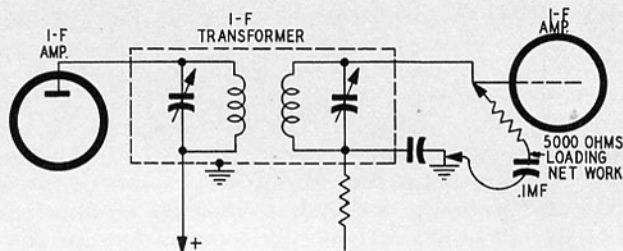

Figure 8

Part of TP-2892F

signal. For this reason, each i-f stage should be adjusted separately, starting with the last stage and working toward the converter (1st det.—osc.). The general FM alignment procedure to be given is based upon the circuit-loading technique and stage-by-stage test-signal injection and adjustment.

The adjustment of the FM detector circuit is given last, since the several different systems require special considerations.



TP-2892G

Figure 9. I-F Transformer with Loading Network Connected

SINGLE-PEAK I-F TRANSFORMERS

Recent developments in FM detectors have produced circuits in which the inherent sensitivity to amplitude modulation is so low that it is possible to utilize i-f systems having relatively sharp response at the center frequency (see figure 10), the essential requirement being that the gain over the desired frequency band is sufficient for satisfactory operation of the system. The desired overall broadness in this type of i-f system is obtained by designing transformers with a lower Q.

An i-f amplifier having these characteristics can be aligned by merely tuning each circuit for maximum output. However, unless the serviceman knows he is dealing with single-peak transformers, it is recommended that the circuit-loading procedure given be followed for all alignments—no error will result from the adjustment of single-peak transformers by this method.

R-F AND OSCILLATOR CIRCUITS

The r-f, oscillator, and converter input circuits inherently provide sufficient damping for the necessary broadness of response, so that these circuits may be adjusted by the ordinary single-peak method.

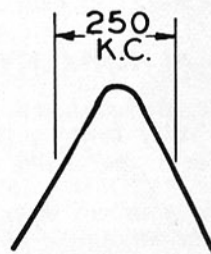

Figure 10

Part of TP-2892F

CONNECTING THE OUTPUT INDICATOR

The circuit to which the output or tuning indicator is connected, as well as the type of indicator used, depends upon the particular FM detector system in the radio. In any case, the i-f, r-f, and oscillator adjustments are made while observing an indicator connected so as to obtain an indication that varies in proportion to the signal strength; it is necessary to disable any circuit that prevents the passage of an AM signal to the circuit where the indicator is connected.

ARMSTRONG DETECTOR

The Armstrong detection system, which is used in many of the FM radios in the field, is characterized by a double-diode frequency discriminator (fundamental circuit shown in figure 11) and one or two limiter stages. The limiter stages remove the greater percentage of amplitude modulation from the i-f signal, so that it is impossible to employ an audio output meter for making the alignment. However, the i-f signal in the limiter stage causes d-c grid-current flow which is dependent upon the amplitude of the signal; therefore, the alignment indicator for all i-f and r-f adjustments can be a 20,000-ohms-per-volt voltmeter, connected across the grid-leak resistor, as shown in figure 12. Note that a 100,000-ohm isolating resistor is connected between the voltmeter prod and the grid circuit, to avoid detuning the input circuit of the limiter. If two limiters are used, the meter is connected to the first limiter for i-f and r-f stage adjustments, then to the last limiter for adjustment of first limiter tuning.

The procedure for adjustment of the Armstrong detector is given under ALIGNMENT OF FM DETECTOR CIRCUITS.

RATIO DETECTOR

The ratio detector (fundamental circuit shown in figure 13) employs two diodes in a somewhat different arrangement from those in the Armstrong detector. The high-capacity condenser, C, charges to an average d-c potential determined by the amplitude of the i-f signal. The tuning indicator may be a 20,000-ohms-per-volt voltmeter connected as shown in figure 13.

The procedure for final adjustment of the ratio detector is given under ALIGNMENT OF FM DETECTOR CIRCUITS.

ADVANCED FM DETECTOR

This detector employs the new FM1000 tube of special design, in a circuit that inherently rejects amplitude modulation and noise.

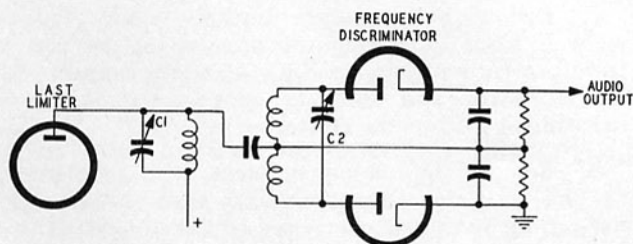

TP-2892H

Figure 11. Armstrong FM Detector, Simplified Circuit

Briefly, the circuit functions as follows: The first and second grids (pins No. 2 and 5) of the FM1000

tube (see figure 14) are used as grid and anode, respectively, of a modified Colpitts oscillator which nominally operates at the center intermediate frequency. The output of the i-f amplifier stages is fed into the injection grid (pin No. 6) of the FM1000 tube. The reactive coupling between the plate circuit of the FM1000 tube and the oscillator circuit causes the oscillator to lock in and follow the frequency variations of the i-f signal. The effect of the foregoing combination of elements is such that, as the oscillator frequency increases, the plate current through the audio load resistor R decreases, and, as the oscillator frequency decreases, the plate current in-

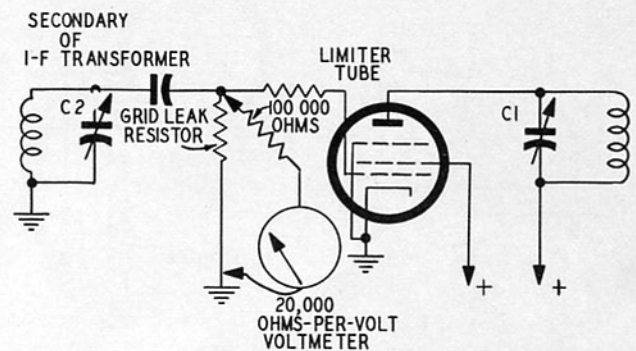

TP-2892J

Figure 12. Limiter Circuit with D-C Indicator Connected

creases. This variation is linear with respect to frequency deviation; the plate current, therefore, produces the same wave shape as the modulation of the FM carrier.

To align the r-f and i-f systems, the oscillating circuit is made inoperative by shorting the oscillator con-

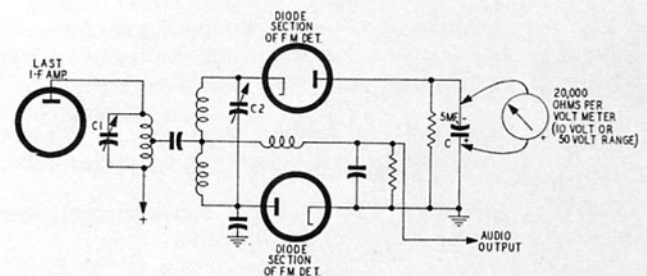

TP-2892K

Figure 13. Ratio Detector with D-C Indicator Connected

trol grid (pin 2) to the chassis, as shown in figure 14; the pentode section then serves as an AM detector, the audio output being proportional to the amplitude of the signal at the last i-f transformer. The i-f, r-f, and oscillator alignment is made with a modulated r-f sig-

nal, and with an ordinary audio output meter connected to the audio output stage of the radio.

The procedure for adjustment of the oscillator portion of the circuit is given under ALIGNMENT OF FM DETECTOR CIRCUITS.

ALIGNMENT OF I-F CIRCUITS

NOTE: Before starting the actual alignment, allow the radio and signal generator to warm up for about 15 minutes.

For the ratio detector, connect network across primary of transformer preceding last i-f amplifier tube.

For the Advanced FM detector, connect network across primary of last i-f transformer (transformer following last i-f amplifier tube).

4. Adjust secondary trimmer for maximum output.

NOTE: Throughout the i-f and r-f alignment, use only sufficient input signal strength to obtain a readable output indication.

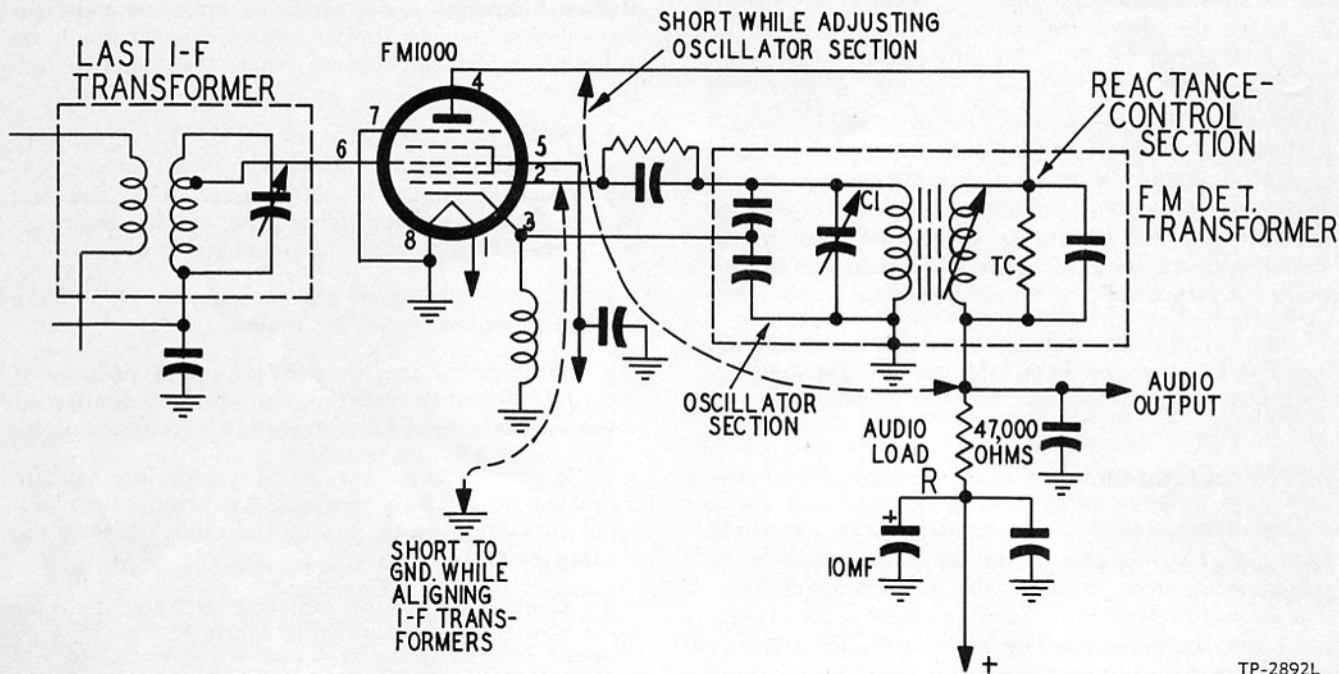

TP-2892L

Figure 14. Advanced FM Detector Circuit

1. Connect the tuning indicator according to the type of detector circuit, as previously described.

2. Connect the signal generator according to the type of detector circuit, as follows:

For the Armstrong detector, connect generator to control grid of last i-f tube preceding the limiter (first limiter, if two limiter stages are used).

For the ratio detector, connect generator to control grid of i-f amplifier preceding last i-f amplifier tube.

For the Advanced FM detector, connect generator to control grid of last i-f amplifier tube.

A modulated signal may be used for adjusting any of the three types of circuits; for the Advanced FM detector, be sure to short-circuit the oscillator portion.

3. Connect loading network previously described, according to the type of circuit, as follows:

For the Armstrong detector, connect network across primary of limiter input transformer (plate of tube to chassis); if two limiters are used, connect load to first limiter.

5. Remove loading network from primary, and connect across secondary of same transformer (control grid of tube to chassis). Then adjust primary trimmer for maximum output.

6. Connect the signal generator to the grid of the tube in the preceding i-f stage and repeat the above loading and tuning procedure, in the same order, for the secondary and primary of the transformer following that tube.

7. Follow this procedure until the final i-f adjustment is made by tuning the primary of the first i-f transformer, with the loading network connected to the secondary, and with the generator connected to the control grid of the converter tube.

8. Remove the loading network, and complete the r-f and oscillator adjustments, as given below, with the tuning indicator connected to the same circuit as for the i-f alignment.

ALIGNMENT OF R-F AND OSCILLATOR CIRCUITS

1. Connect a 68- or 70-ohm terminating resistor across the output terminals of the signal-generator

cable. Connect the generator output leads to the FM aerial connectors.

NOTE: If the radio is equipped with an external all-purpose aerial-matching transformer, remove this transformer and feed the signal directly into the FM aerial coil.

2. Set the generator frequency and the radio dial for 105 mc.; a modulated signal may be used.

3. Adjust shunt trimmer of FM oscillator circuit for maximum output.

4. To check the low-frequency tracking of the oscillator, set the radio dial to 88 mc. Tune in the signal by swinging the generator dial about this frequency. If the signal is heard with the generator set at 88 mc., no adjustment of oscillator tracking is required. If the signal is heard with the generator set below 88 mc., spread the turns of the oscillator coil until the signal is received with a generator setting of 88 mc. If the signal is heard with the generator set above 88 mc., make the adjustment by compressing the turns of the oscillator coil.

NOTE: Do not bend the coil excessively, since only a slight change is necessary at these frequencies.

5. Repeat the shunt trimmer adjustment and low-frequency tracking adjustment of the oscillator (steps 1 to 4) until no further improvement is obtained (the last adjustment made should be that of the shunt trimmer).

6. Set the generator and radio dials for 105 mc., and adjust the shunt trimmer of the converter (mixer) grid circuit for maximum output. Rock the radio tuning control back and forth while making this adjustment.

NOTE: If the FM circuit has no tuned r-f stage, make this adjustment by feeding in the generator signal with the two dipole aerials described in step 7.

7. Make two simple dipole aerials, to feed the signal from the generator into the radio. Each dipole may consist of two 30-inch lengths of rubber-covered wire. Connect one length of wire to each of the generator terminals, and one length to each of the FM aerial terminals on the radio; space the dipoles several feet apart. Using the 105-mc. input frequency, adjust the shunt trimmer of the r-f stage grid circuit for maximum output.

8. Set the signal generator and radio dials for 92 mc. Check the tracking of the converter tuned-grid circuit by means of a tuning wand. If the signal output decreases when either the brass or iron end is inserted in the coil, the tracking of this circuit is satisfactory. If the output is increased with brass inserted, spread the turns of the coil; if the output is increased with iron inserted, compress the turns of the coil.

9. If the FM circuit employs a tuned r-f stage, adjust the tracking of this circuit at 92 mc. by the same procedure used for the converter input circuit (step 8).

10. Repeat the foregoing adjustments of r-f and converter circuits until no further improvement in output can be obtained (make the high-frequency trimmer adjustments last).

ALIGNING LAST LIMITER STAGE

For circuits having two limiter stages, after the i-f and r-f alignment has been made with the indicator connected to the first limiter, the last limiter should be adjusted before proceeding with the detector adjustments.

1. Since the original i-f setting of the signal generator was changed for the r-f alignment, the d-c tuning indicator should be left connected to the first limiter circuit until the signal generator has been correctly reset to the center intermediate frequency.

2. Connect the signal generator to the grid of the i-f tube preceding the first limiter.

3. Connect the loading network to the primary of the i-f transformer working into the first limiter, at the same point used for starting the i-f alignment.

4. Reset the generator to the center intermediate frequency by carefully tuning the generator for maximum d-c voltage on the tuning indicator. Remove the loading network.

5. Connect the tuning indicator to the grid circuit of the last limiter, as shown in figure 12.

6. Connect the signal generator to the grid of the first limiter tube.

7. Connect the loading network to the primary of the i-f transformer working into the last limiter. Adjust the secondary tuning of this transformer for maximum voltage on the indicator.

8. Connect the loading network to the secondary of the same transformer, and adjust the primary tuning for maximum. Remove the tuning indicator and loading network.

ALIGNMENT OF FM DETECTOR CIRCUITS

The final step in the FM alignment is the adjustment of the FM detector circuit. When making these adjustments, use an all-fibre adjusting tool.

NOTE: When an FM signal generator and oscilloscope are available, it is recommended that the detector adjustments be made, or checked, visually, in order to observe the overall linearity of the detector output with a frequency-modulated signal. The following information is based upon the most satisfactory methods found for making the adjustments with the service-type AM signal generator.

ARMSTRONG DETECTOR

This detector should be adjusted for minimum audio output at the center intermediate frequency, while using a modulated signal. The audio output meter may be connected to the audio output stage in the usual manner. Since the original i-f setting of the signal generator was changed for making the r-f alignment, the d-c tuning indicator should be left connected to the limiter circuit until the signal generator has been correctly reset to the center intermediate frequency.

1. Connect the signal generator to the control grid of the i-f tube preceding the limiter tube, at the same point used for starting the i-f alignment.

NOTE: If the circuit has two limiters, and the signal-generator setting has not been disturbed since the adjustment of the last limiter stage, disregard steps 1, 2, and 3 of this procedure; connect the generator to the grid of the last limiter tube, and start with step 4.

2. Connect the loading network across the primary of the last limiter input transformer, at the same point used for starting the i-f alignment.

3. Reset the generator to the center intermediate frequency by carefully tuning the generator for maximum d-c voltage on the tuning indicator. Remove the loading network and d-c voltmeter.

4. Turn the discriminator balancing trimmer (C in figure 11) down tightly, thus detuning the discriminator tuned circuit.

5. Set the generator output just high enough to provide a reliable indication on the *audio* output meter, and adjust the plate-circuit trimmer (C¹ in figure 11) for maximum audio output.

6. Adjust the balancing trimmer C² for minimum audio output; the output should increase on either side of the correct trimmer setting (the ear is usually just as reliable as the meter for this adjustment, since the signal input can be kept very low).

RATIO DETECTOR

1. Leave the d-c voltmeter connected to the high-capacity condenser C (see figure 13). Use 10-volt or 50-volt range.

2. Connect the signal generator to the control grid of the i-f amplifier preceding the last i-f amplifier tube, at the same point used for starting the i-f alignment.

3. Connect the loading network across the primary of transformer preceding last i-f amplifier tube, at the same point used for starting the i-f alignment.

4. Reset the generator to the center intermediate frequency by carefully tuning the generator for maxi-

mum d-c voltage on the tuning indicator. Remove the loading network.

5. Adjust the diode-circuit trimmer (C² in figure 13) for maximum d-c voltage indication.

6. Adjust the plate-circuit trimmer, C¹, of the last i-f amplifier, for maximum d-c voltage indication. Remove the d-c voltmeter.

7. "Touch up" the adjustment of C² to obtain minimum audio output; the output should increase on either side of the correct trimmer setting (the ear is usually just as reliable as the meter for this adjustment, since the signal input can be kept very low).

ADVANCED FM DETECTOR

This detector circuit is adjusted by tuning its oscillator section to zero beat with the generator signal, which is set to the center intermediate frequency and fed into the i-f stage ahead of the detector.

Leave the audio output meter connected to the audio output stage, as for the i-f alignment.

1. Connect the signal generator to the control grid of the last i-f amplifier tube, at the same point used for starting the i-f alignment.

2. Connect the loading network to the primary of the last i-f transformer (transformer following last i-f tube), at the same point used for starting the i-f alignment.

3. See that the jumper is connected across the oscillator section (pin 2 of FM1000 tube to chassis), as used for the i-f alignment.

4. Using a modulated signal, reset the generator to the center intermediate frequency by carefully tuning the generator for maximum audio output; keep the input signal low for this adjustment.

5. Remove the jumper from pin 2 to chassis; also remove the loading network and the audio output meter.

6. Short out the reactance-control circuit of the detector by connecting the jumper across the plate coil, from the plate (pin 4) of the FM1000 tube to the audio load resistor R, as shown in figure 14.

7. Turn off the signal-generator modulation, and adjust the oscillator trimmer (C¹ in figure 14) for zero beat; the beat note heard should increase in frequency on either side of the correct trimmer adjustment.

8. Remove jumper used for step 7. Adjust the tuning core, TC, or the reactance-control section, for zero beat. The generator signal must be kept very low for this adjustment. When a single, sharp zero beat is obtained, the adjustment is correct.

REPLACEMENT OF TUBES IN MODEL 7070 SIGNAL GENERATOR

To replace tubes, first remove the cross-recess-head screws from around the edges of the front panel. Tilt the panel forward, remove the power-transformer plug from the socket in the line-filter shield, then remove the signal generator from its case.

Since the r-f oscillator is well stabilized, replacement of the 6C4 tube should not cause appreciable change in calibration; however, because of certain variations in tubes of different makes, it is advisable, after replacing the oscillator tube, to check the calibration against stations of known frequencies in the broadcast and short-wave bands. If the calibration has shifted noticeably, try another tube (a tube of a different make may restore the calibration). If the desired accuracy is not obtainable with available tubes, calibration-correction adjustments may be made as described below.

CALIBRATION ADJUSTMENTS

A separate trimmer condenser is provided for each r-f band, for correcting the calibration of the Model 7070 Signal Generator. Remove the signal generator from its case, as for replacement of tubes; the adjusting trimmers are located as shown in figures 15 and 16. To make accurate adjustments, it is necessary to use some calibrated signal source for obtaining a "standard" signal, against which the signal frequency of the Model 7070 can be compared; the signals are picked up on a radio that is capable of responding at the various frequencies to be used in making the adjustments. The calibration of the radio should be suffi-

ciently accurate to permit identification of the frequency of the standard signal at each desired calibration point.

Any one of the following combinations may be used, according to the equipment available.

1. A crystal-controlled frequency standard and an all-wave radio; connect as shown in figure 18A.
2. Another r-f signal generator, known to be accurately calibrated, and an all-wave radio. See figure 18B.

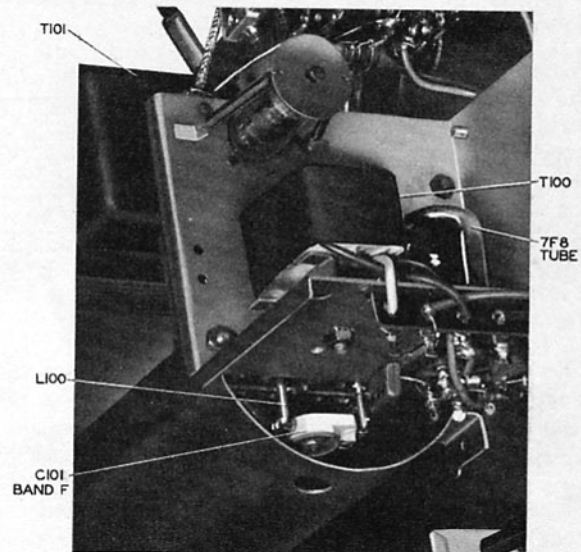

TP-2891

Figure 16. Trimmer-Condenser Location—Band F

3. An all-wave radio with aerial connected, for picking up standard signals from broadcast or code stations of known frequencies. See figure 18C.

The adjustment of each trimmer should be made near the high-frequency end of the band to be calibrated. No special sequence of adjustments need be observed, since each trimmer and coil circuit is independent of the others.

Allow the Signal Generator and associated equipment to warm up for at least ten minutes. Turn off the audio modulation. Set the frequency standard to the desired frequency, and tune in the signal on the radio; the signal from the Model 7070 Signal Generator can then be zero beat against the standard signal.

With the BAND SWITCH of the Model 7070 properly set, turn the dial to the point at which the frequency is to be adjusted. Turn the correct calibrating trimmer until the beat signal is heard in the radio, then carefully adjust the trimmer for zero beat; the sharpest zero beat indication will be obtained if the two signals are moderately weak. Repeat the adjustments for each band.

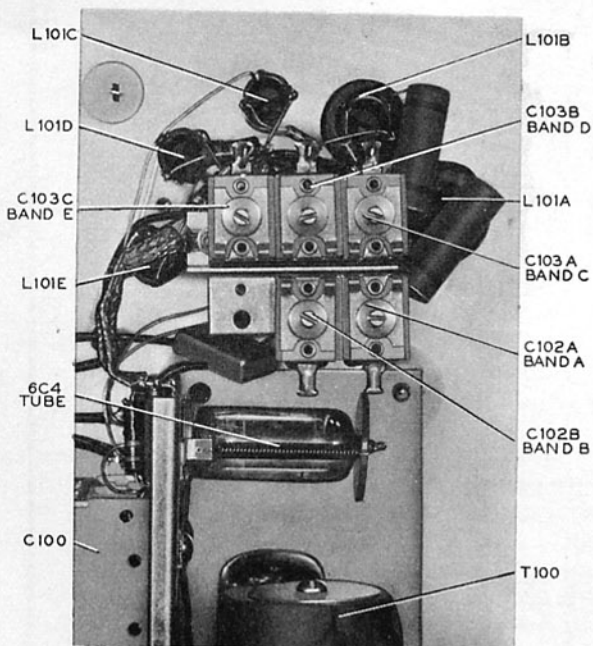

TP-3737

Figure 15. Trimmer-Condenser Locations—Bands A, B, C, D and E

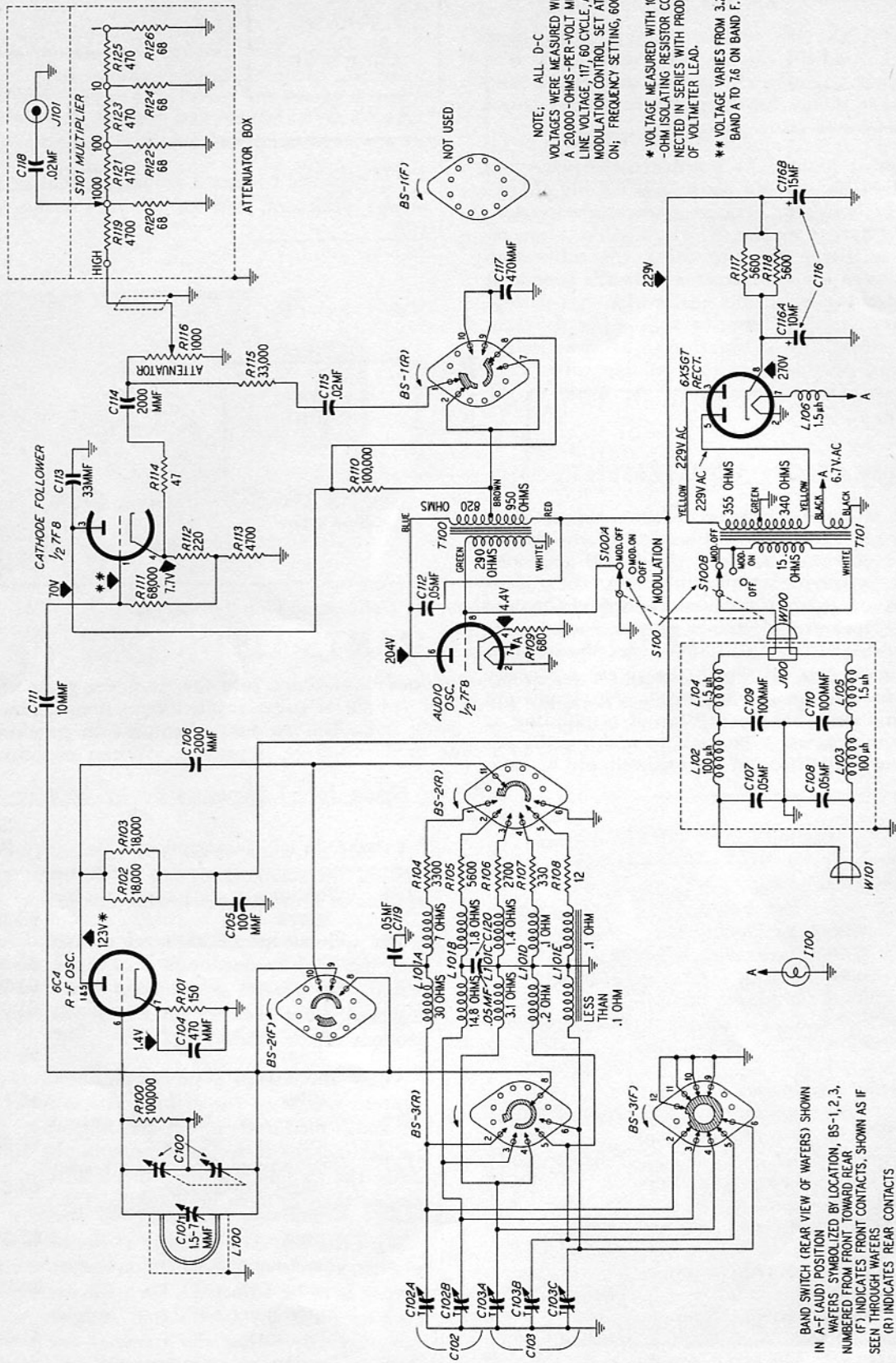

NOTE: ALL D-C VOLTAGES WERE MEASURED WITH A 20000-OHMS-PER-VOLT METER; LINE VOLTAGE, 117, 60 CYCLE, AC; MODULATION CONTROL SET AT MOD ON; FREQUENCY SETTING, 600KC.

* VOLTAGE MEASURED WITH 100000-OHM ISOLATING RESISTOR CONNECTED IN SERIES WITH PROD END OF VOLT-METER LEAD.

** VOLTAGE VARIES FROM 3.2 ON BAND A TO 7.6 ON BAND F.

BAND SWITCH (REAR VIEW OF WAFERS) SHOWN IN A-F (AUD) POSITION
 WAFERS SYMBOLIZED BY LOCATION, BS-1, 2, 3, NUMBERED FROM FRONT TOWARD REAR
 (F) INDICATES FRONT CONTACTS, SHOWN AS IF SEEN THROUGH WAFERS
 (R) INDICATES REAR CONTACTS

Figure 17. Philco R-F Signal Generator, Model 7070, Complete Schematic

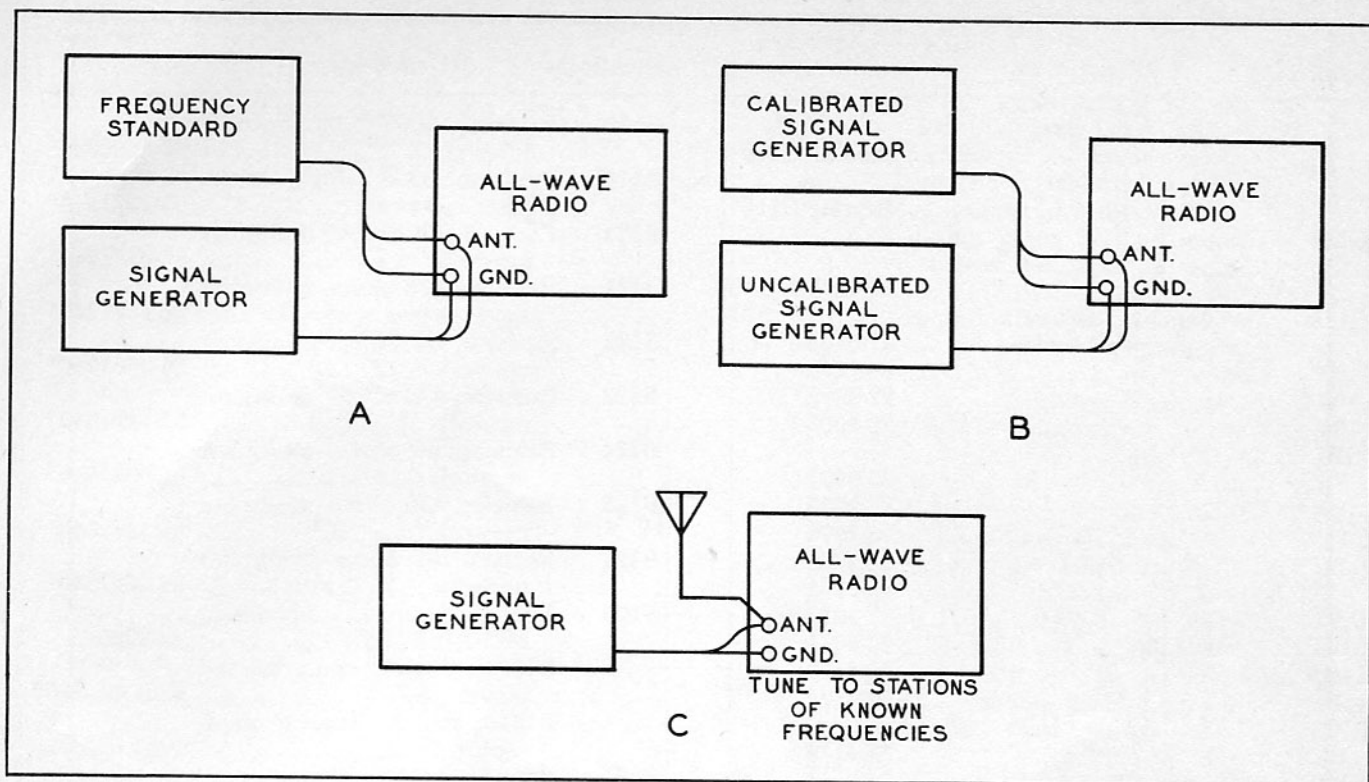

Figure 18. Equipment Combinations for Calibrating Signal Generator

TP-2892E

REPLACEMENT PARTS LIST

NOTE: Parts marked with an asterisk (*) are general replacement items, and the numbers may not be identical with those on factory assemblies; also, the electrical values of some replacement items furnished may differ from the values indicated in the schematic and parts list. The values substituted in any case are so chosen that the operation of the instrument will be either unchanged or improved. When ordering replacements, use only the "Service Part No." in this parts list.

Symbol	Description	Service Part No.
BS	Band switch, 3-section	42-1737
	BS-1: wafer, band-switch	Part of BS
	BS-2: wafer, band-switch	Part of BS
	BS-3: wafer, band-switch	Part of BS
C100	Condenser, tuning, 2-gang	31-2642
C101	Condenser, trimmer, band F oscillator	31-6480-2
C102	Condenser, 2-section, trimmer	31-6476-12
	C102A: condenser, trimmer, band A osc.	Part of C102
	C102B: condenser, trimmer, band B osc.	Part of C102
C103	Condenser, 3-section, trimmer	31-6358
	C103A: condenser, trimmer, band C osc.	Part of C103
	C103B: condenser, trimmer, band D osc.	Part of C103
	C103C: condenser, trimmer, band E osc.	Part of C103
C104	Condenser, 470 mmf, r-f by-pass	60-10475417*

Symbol	Description	Service Part No.
C105	Condenser, 100 mmf, r-f by-pass	60-10105417*
C106	Condenser, 2000 mmf, r-f osc. plate, feedback	60-20205314*
C107	Condenser, .05 mf, line filter..	61-0122*
C108	Condenser, .05 mf, line filter..	61-0122
C109	Condenser, 100 mmf, line filter	60-10105417*
C110	Condenser, 100 mmf, line filter	60-10105417*
C111	Condenser, 10 mmf, output coupling, r-f osc.	60-00105417*
C112	Condenser, .05 mf, a-f osc. plate, feedback	61-0186*
C113	Condenser, 33 mmf, r-f by-pass	60-00305417*
C114	Condenser, 2000 mmf, output coupling, cath. fol.	60-20205314*
C115	Condenser, .02 mf, output coupling, a-f osc.	61-0108*
C116	Condenser, electrolytic, 2-section	30-2552*

REPLACEMENT PARTS LIST (Continued)

Symbol	Description	Service Part No.
	C116A: condenser, 10 mf, power filter, 1st section	Part of C116
	C116B: condenser, 15 mf, power filter, 2nd section	Part of C116
C117	Condenser, 470 mmf, amplitude limiting, α -f modulation	60-10475417*
C118	Condenser, .02 mf, output coupling, r-f and α -f	61-0108*
I100	Lamp, pilot	34-2040*
J100	Socket, α -c, line filter	27-6212
J101	Connector, female, OUTPUT..	76-2003-1
L101	Oscillator-coil assembly	
	L101A: oscillator coil, band A	32-3901
	L101B: oscillator coil, band B	32-4009
	L101C: oscillator coil, band C	32-3902
	L101D: oscillator coil, band D	32-3903
	L101E: oscillator coil, band E	32-3904
L102	Choke, 100 μ h, line filter	32-4011
L103	Choke, 100 μ h, line filter	32-4011
L104	Choke, 1.5 μ h, line filter	32-4178
L105	Choke, 1.5 μ h, line filter	32-4178
L106	Choke, 1.5 μ h, r-f isolation, rect. fil.	32-4178
R100	Resistor, 100,000 ohms, grid leak, r-f osc.	66-4103340*
R101	Resistor, 150 ohms, cathode, r-f osc.	66-1153340*
R102	Resistor, 18,000 ohms, voltage-dropping	66-3185340*
R103	Resistor, 18,000 ohms, voltage-dropping	66-3185340*
R104	Resistor, 3300 ohms, degeneration, band A	66-2333340*
R105	Resistor, 5600 ohms, degeneration, band B	66-2563340*
R106	Resistor, 2700 ohms, degeneration, band C	66-2273340*
R107	Resistor, 330 ohms, degeneration, band D	66-1333340*
R108	Resistor, 12 ohms, degeneration, band E	66-0123340*
R109	Resistor, 680 ohms, cathode α -f osc.	66-1681340*
R110	Resistor, 100,000 ohms, amplitude limiting, α -f modulation	66-4103340*
R111	Resistor, 68,000 ohms, grid leak, cath. fol.	66-3683340*
R112	Resistor, 220 ohms, bias, cath. fol.	66-1223340*
R113	Resistor, 4700 ohms, load, cath. fol.	66-2473340*
R114	Resistor, 47 ohms, cathode isolating, cath. fol.	66-0473340*
R115	Resistor, 33,000 ohms, output coupling, α -f osc.	66-3333340*
R116	Potentiometer, 1000 ohms, ATTENUATOR	33-5533
R117	Resistor, 5600 ohms, power filter	66-2565340*

Symbol	Description	Service Part No.
R118	Resistor, 5600 ohms, power filter	66-2565340*
R119	Resistor, 4700 ohms, multiplier network	66-2471340*
R120	Resistor, 68 ohms, multiplier network	66-0681340*
R121	Resistor, 470 ohms, multiplier network	66-1471340*
R122	Resistor, 68 ohms, multiplier network	66-0681340*
R123	Resistor, 470 ohms, multiplier network	66-1471340*
R124	Resistor, 68 ohms, multiplier network	66-0681340*
R125	Resistor, 470 ohms, multiplier network	66-1471340*
R126	Resistor, 68 ohms, multiplier network	66-0681340*
S100	Switch, rotary, 3-position, MODULATION	42-1769
	S101A: switch contacts, α -c power	Part of S100
	S101B: switch contacts, modulator	Part of S100
S101	Switch, rotary, 5-position, MULTIPLIER	42-1738
T100	Transformer, modulator	32-9610
T101	Transformer, power	32-8276-1
W100	Line cord (with plug) external	L3183-1
W101	Line cord (with plug), internal	L3183-2

MISCELLANEOUS

Box, termination, output cable	54-4438
Cable, output	41-3730
** { Connector, male, output cable	76-2895
{ Sleeve, male connector ..	56-4559
Coupling, tuning-condenser shaft	56-3183
Cover, output-cable terminal box	54-4437
Foot (8), mounting	54-4240
Handle assembly	76-1979
Knob (4), control	54-4281
Knob, tuning	54-7281
Panel, front	56-2684
Plate, model information	56-3187
Plate, name, "PHILCO"	76-2114
Pointer, lucite	54-4262
Post (2), binding, terminal box	76-2896
Resistor, 68 ohms \pm 5%, 1/2 w, output lead	66-0683240*
Shaft assembly, vernier drive	31-2700
Socket assembly, pilot light..	76-1658
Socket, Loktal	27-6213
Socket, miniature	27-6203-1
Socket, octal	27-6199*

** These two items should be ordered together.

ACCESSORY DIVISION

PHILCO CORPORATION

PHILADELPHIA, PA.

Part No. 39-7896.

Printed in U. S. A.